

MARINE CEILING PANEL SYSTEM LAUTEX LTK-340 B-15 / A-30 DECK

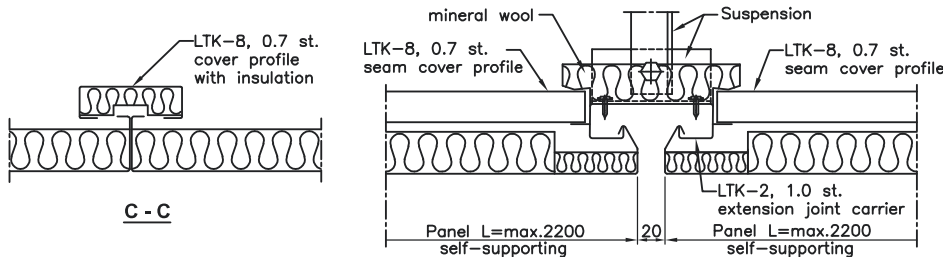
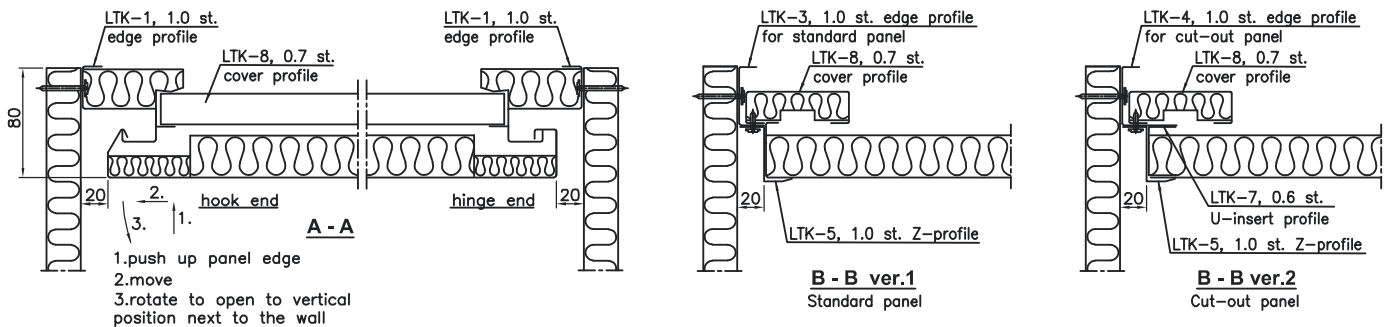
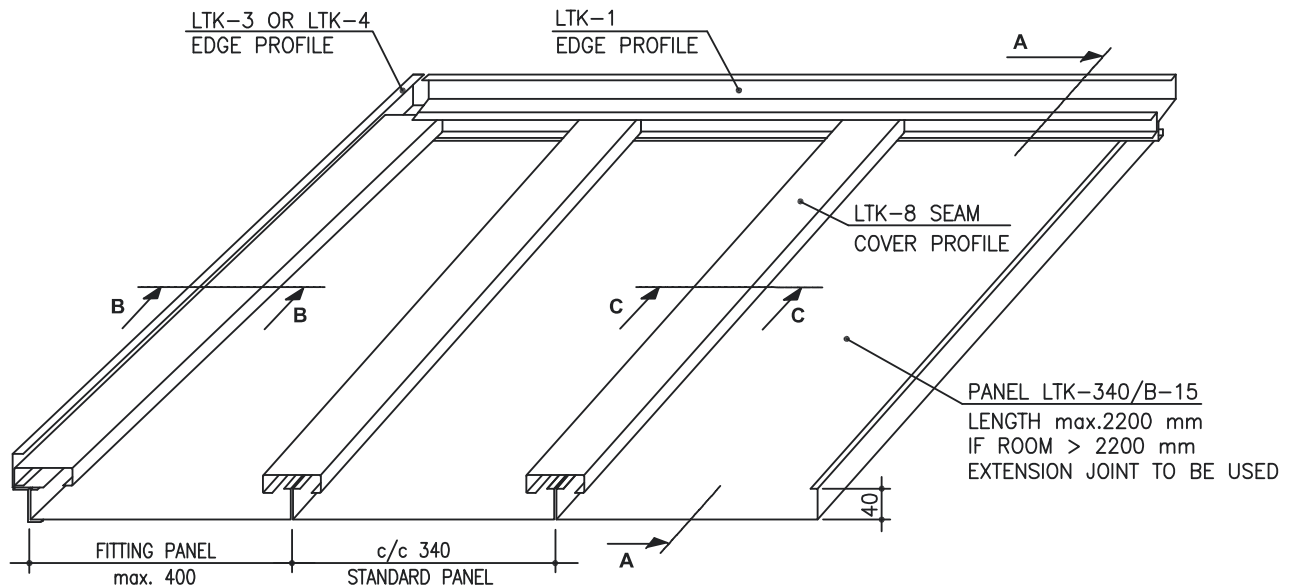

Ceiling extension joint
If the panel is longer than 2200mm

LTK-340 PANELS / CLASSIFICATION "B-15"

Material	0.6 mm galvanized steel
Width	standard panel 340 mm, fitting panel max.400mm
Height	panel height 40mm
Length	L=max.2200mm, if L > 2200mm – extension joint to be used
Insulation	non-combustible mineral wool, s=30mm(middle part) and s=15mm(ends)
Weight	Approx. 10.1 kg/m ²
Finish	stove enamelled surface according to well-known colour charts
Protective film	the surface is provided with a protective film
End bendings	hook end and hinge end on opposite sides easy to remove without tools
Service hatch	each panel is easy to open and remove without tools
Other special solutions	special B-15 class certified solutions please contact our technical information department